

THE REPRODUCTION, DISTRIBUTION AND UTILIZATION OF THIS DOCUMENT, AS WELL AS THE COMMUNICATION OF ITS CONTENTS TO OTHERS WITHOUT EXPLICIT AUTHORIZATION IS PROHIBITED. OFFENDERS WILL BE HELD LIABLE FOR THE PAYMENT OF DAMAGES. ALL RIGHTS RESERVED IN THE EVENT OF THE GRANT OF A PATENT, UTILITY MODEL OR DESIGN. (PER ISO 18016)

REVISIONS			
REV	DESCRIPTION	DATE	APPROVED
A	(1) ADDED DIMENSION (2) DRAWING TITLE WAS "NIPPLE ASSEMBLY, HOSE SPLICER, GH134"	1999-10-04 R.D.G.	EN-F19366 DP-24901

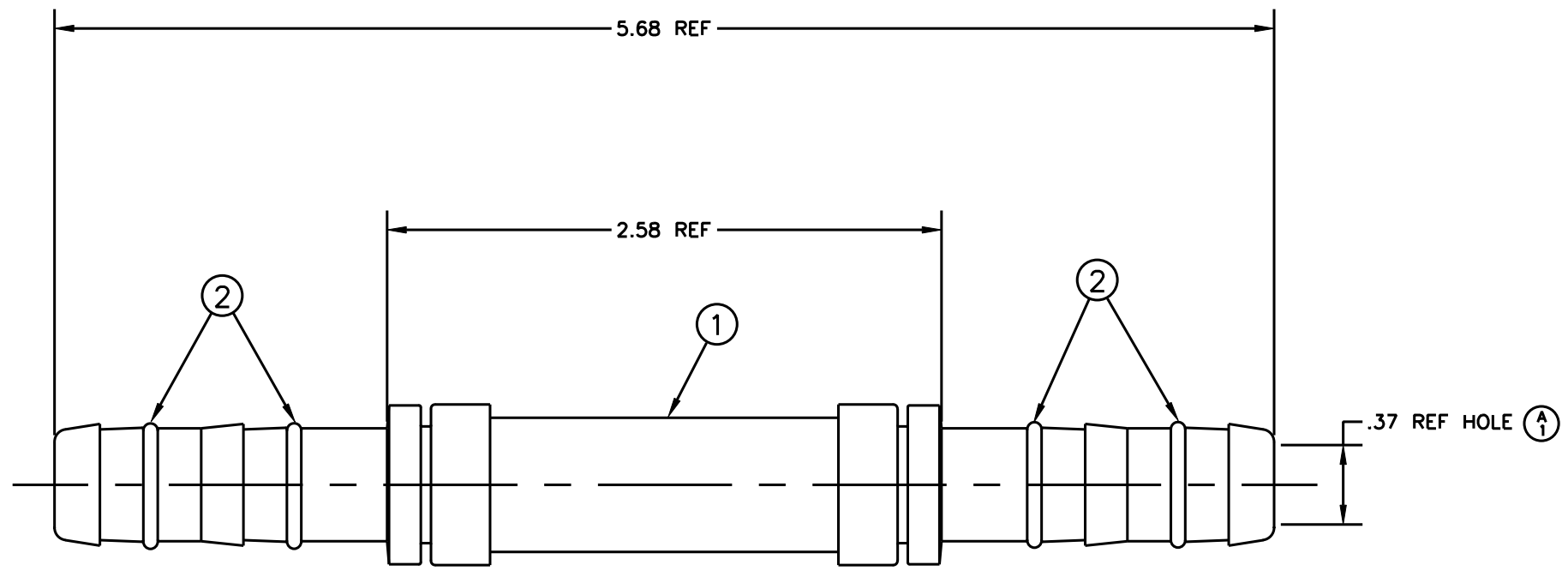

INCH

1. PROCESS AS FOLLOWS:  
LUBRICATE O'RINGS AND ASSEMBLE ON NIPPLE AS SHOWN

FJ3045-1010S	FJ2045-1010S	1F40106-10		
AEROQUIP PART NUMBER	(1) NIPPLE ASSEMBLY	(2) O'RING (4 REQ'D)		
LIST OF MATERIALS				
ITEM NO.	MATERIAL	DRAWN M. HILVERS	<b>Danfoss</b> FLUID CONVEYANCE DIVISION	
1	STEEL	CHECKED J. BAHNSEN		
2	HNBR	APPROVED J. BAHNSEN	DRAWING TITLE <b>FITTING ASSEMBLY (A2)</b> HOSE SPLICER, GH134 HOSE	
		RELEASE DATE 1999-09-24		
		EN-F19203 RPS-5801	SIZE A2	DRAWING NUMBER FJ3045-1010S
		THIRD ANGLE PROJECTION	SCALE 2/1	DIST U
		ITEM TYPE: DTZA	CAGE CODE 01276	SHEET NO

REV. A  
 SH.  
 FJ3045-1010S  
 DWG. NO.

