

THE REPRODUCTION, DISTRIBUTION AND UTILIZATION OF THIS DOCUMENT, AS WELL AS THE COMMUNICATION OF ITS CONTENTS TO OTHERS WITHOUT EXPLICIT AUTHORIZATION IS PROHIBITED. OFFENDERS WILL BE HELD LIABLE FOR THE PAYMENT OF DAMAGES. ALL RIGHTS RESERVED IN THE EVENT OF THE GRANT OF A PATENT, UTILITY MODEL OR DESIGN. (PER ISO 18016)

REVISIONS			
REV	DESCRIPTION	DATE	APPROVED
A	INITIAL RELEASE SUPERSEDES PRE-PRODUCTION DRAWING FJ3019-01-1012S REV "NONE"	1999-08-27	EN-F19222 DP-1256

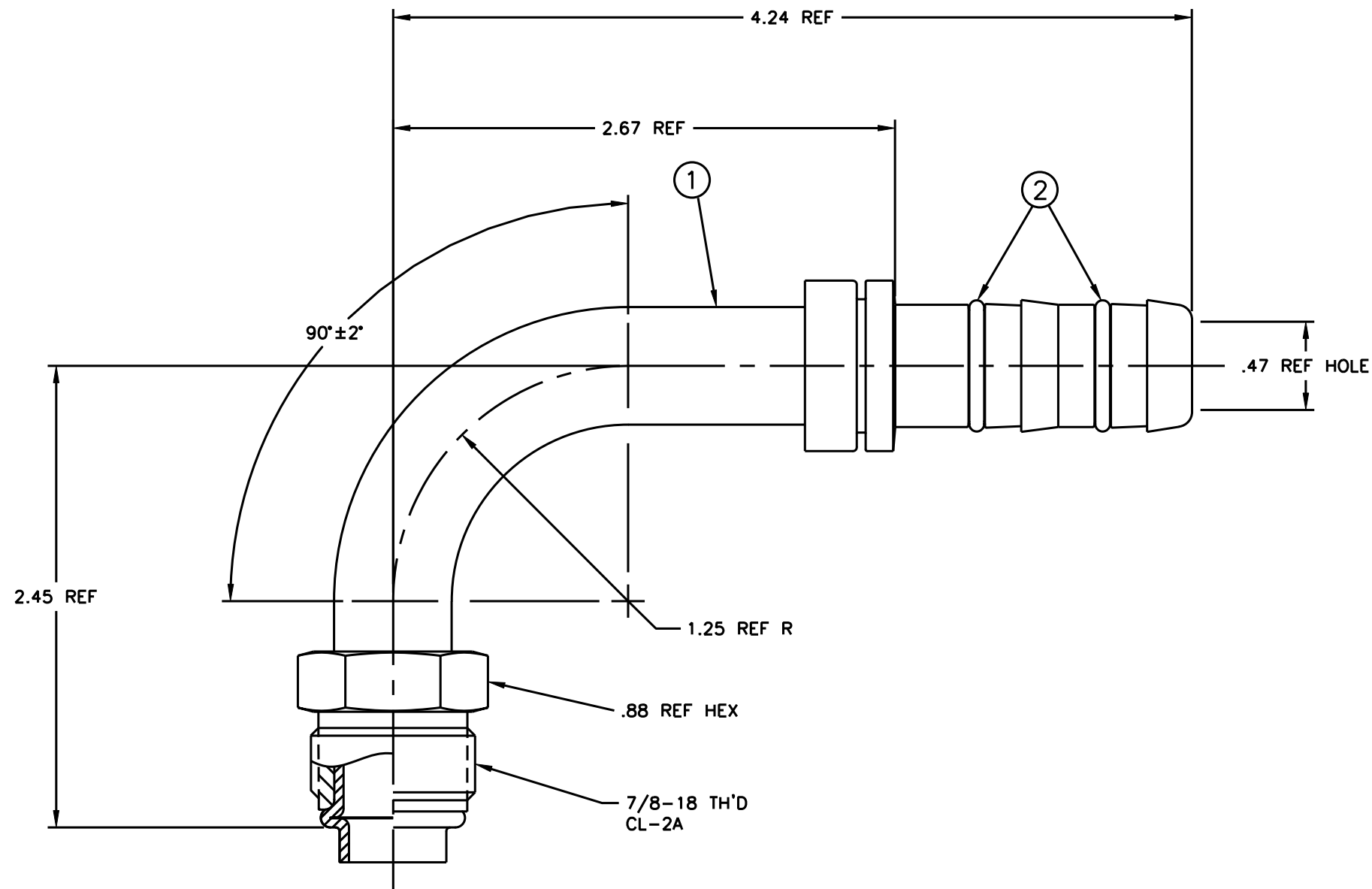

FN

4

REV. A

SH.

DWG. NO. FJ3019-01-1012S

INCH

1. PROCESS AS FOLLOWS:
(a) LUBRICATE O'RINGS AND ASSEMBLE AS SHOWN.

FJ3019-01-1012S	FJ2019-01-1012S	1F40106-12			
AEROQUIP PART NUMBER	① NIPPLE ASSEMBLY	② O'RINGS (2 REQ'D)			
LIST OF MATERIALS					
ITEM NO.	MATERIAL	DRAWN T. HARTFORD			
1	STEEL	CHECKED J. BAHNSEN			
2	HNBR	APPROVED J. GRAU			
		RELEASE DATE 1999-09-09			
		EN-F19222 DP-1256			
		THIRD ANGLE PROJECTION			
		SCALE 2:1	DIST U	CAGE CODE 01276	SHEET NO

Danfoss FLUID CONVEYANCE DIVISION

DRAWING TITLE
FITTING ASSEMBLY
90° SAE MALE O-RING PILOT (SHORT)
GH134 HOSE

SIZE A2 DRAWING NUMBER FJ3019-01-1012S REV A