

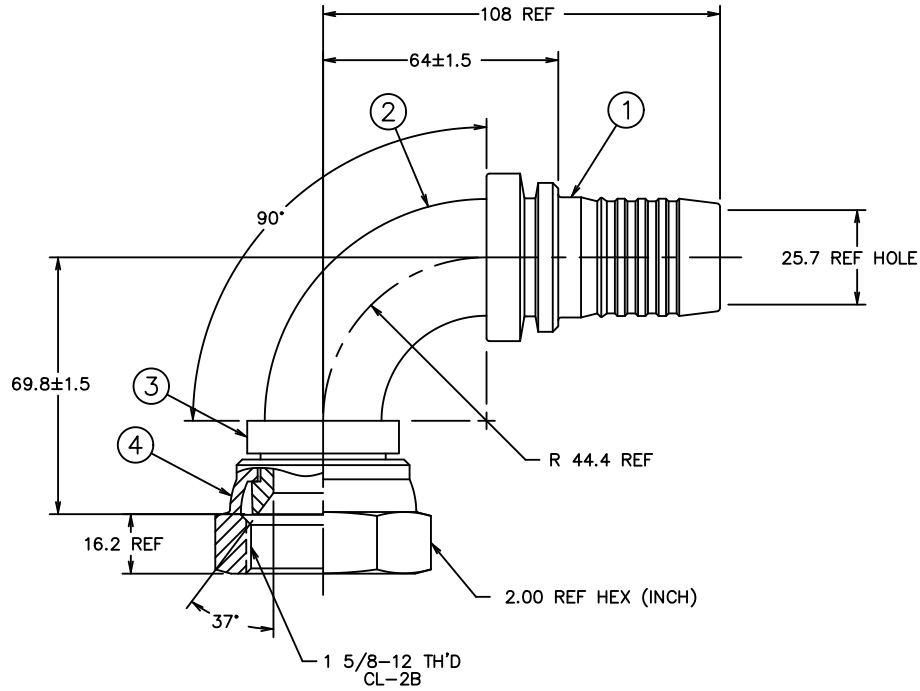

| REVISIONS | | | |
|-----------|---|-------------------|--------------------|
| REV | DESCRIPTION | DATE | APPROVED |
| H | REDRAWN - SUPERSEDES 1SA_FJB_SHEET 1/2 REV."G" FOR 1SA20FJB20 (1)NOTE # 1(C) WAS: "CRIMP NUT PER ACES 2409P2" | 11-9-95 | EN-F16025 DP-24900 |
| J | 1) NOTE #1(b) WAS ZINC PLATE PER ACES 2751 | 2020-06-18 ARK | CO-0204147 |



| | |
|----------|----------|
| 108 | 4.25 |
| 69.8±1.5 | 2.75±.06 |
| 64±1.5 | 2.52±.06 |
| 44.4 | 1.75 |
| 25.7 | 1.01 |
| 16.2 | .64 |
| MM | INCH |

CONVERSION

METRIC

| 1SA20FJB20 | 1F40014-2020AB | FC2962-20S | FC2775-2020S | 210204-20S |
|---|----------------|--|--------------|------------|
| AEROQUIP PART NUMBER | ① NIPPLE | ② ELBOW \triangle | ③ SHOULDER | ④ NUT |
| LIST OF MATERIALS | | | | |
| ITEM NO. | MATERIAL | DRAWN R.D. GARRETT CHECKED M. MOLINA APPROVED R.D. GARRETT RELEASE DATE 1995-11-10 EN-F16025 DP-24900 THIRD ANGLE PROJECTION | | |
| 1 | STEEL |  FLUID CONVEYANCE DIVISION DRAWING TITLE NIPPLE ASSEMBLY 90°, SAE 37° SWIVEL 2781 HOSE SIZE A2 DRAWING NUMBER 1SA20FJB20 REV J SCALE 1/1 DIST U CAGE CODE 01276 SHEET 1 | | |
| 2 | STEEL | | | |
| 3 | STEEL | | | |
| 4 | STEEL | | | |
| THE REPRODUCTION, DISTRIBUTION AND UTILIZATION OF THIS DOCUMENT AS WELL AS THE COMMUNICATION OF ITS CONTENTS TO OTHERS WITHOUT EXPLICIT AUTHORIZATION IS PROHIBITED. OFFENDERS WILL BE HELD LIABLE FOR THE PAYMENT OF DAMAGES. ALL RIGHT RESERVED IN THE EVENT OF THE GRANT OF A PATENT, UTILITY MODEL OR DESIGN. (PER ISO 16016) | | | | |

\triangle CAN BE MADE FROM TUBING PER SPECIFICATIONS ON ELBOW DRAWING.

1. PROCESS AS FOLLOWS:
 (a) BRAZE PER ACES 2814.
 (b) ZINC PLATE PER ES 2751DB.
 (c) CRIMP NUT PER ACES 2813.

