

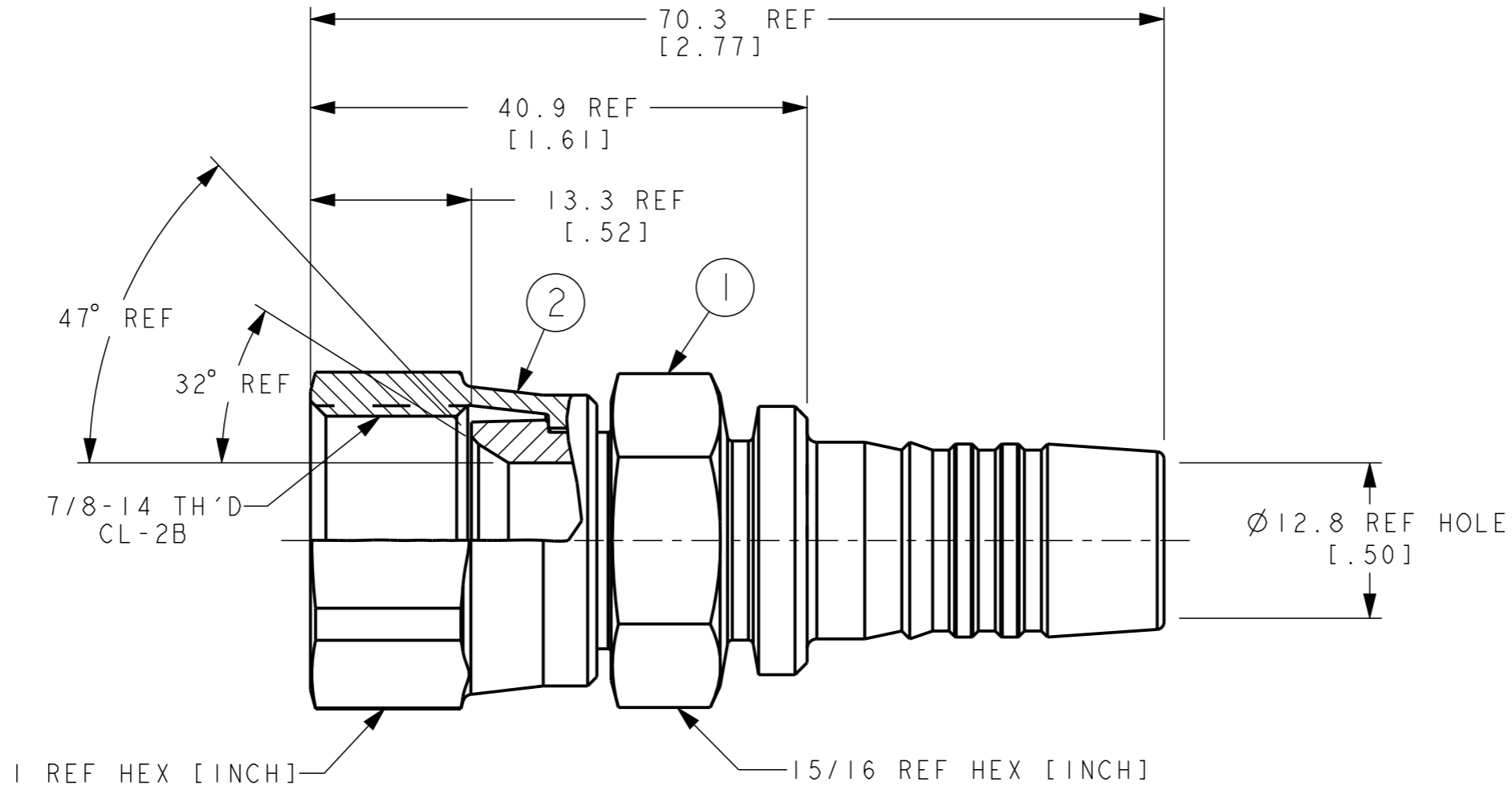

PART NUMBER	SURFACE AREA	MASS
ISA10FJ10	10403 mm <sup>2</sup>	95 g

REVISIONS			
REV	DESCRIPTION	DATE	APPROVED
E	REDRAWN. UPDATED TO LATEST FORMAT TO SHOW DUAL SEATING NIPPLE DESIGN.	2023-07-15 VSP	CO-0229730



ISA10FJ10	IF40000A1010-S	210204-10S			
PART NUMBER	① NIPPLE	② NUT			

LIST OF MATERIALS

ITEM NO.	MATERIAL	FLUID CONVEYANCE DIVISION MAUMEE, OHIO U.S.A.		DRAWN V. PATIL	
1	STEEL			CHECKED V. PATIL	
2	STEEL			APPROVED B. JADHAV	
				RELEASE DATE 2023-07-15	
				DRAWING INTERPRETATION PER ES 10	
		DRAWING TITLE		NIPPLE ASSEMBLY	
		CO-0229730		HIGH PRESSURE SAE 37° FEMALE SWIVEL 2781 HOSE	
		CAGE CODE 01276		DRAWING NUMBER	
		THIRD ANGLE PROJECTION		ISA10FJ10	
		SIZE A3		REV	
		SCALE 2/1		E	
		SHEET 1			

2. PROCESS AS FOLLOWS:  
(a) CRIMP NUT PER ACES 2813.

1. DIMENSIONS ARE IN MILLIMETERS [INCHES].

THE REPRODUCTION, DISTRIBUTION, AND UTILIZATION OF THIS DOCUMENT AS WELL AS THE COMMUNICATION OF ITS CONTENTS TO OTHERS WITHOUT EXPLICIT AUTHORIZATION IS PROHIBITED. OFFENDERS WILL BE HELD LIABLE FOR THE PAYMENT OF DAMAGES. ALL RIGHTS RESERVED IN THE EVENT OF THE GRANT OF A PATENT, UTILITY MODEL OR DESIGN. (PER ISO 16016)