

| | | |
|-------------|----------------------|------|
| PART NUMBER | SURFACE AREA | MASS |
| IGA5FJ4 | 6230 mm ² | 35 g |

| REVISIONS | | | |
|-----------|---|-------------------|------------|
| REV | DESCRIPTION | DATE | APPROVED |
| B | REDRAWN. UPDATED TO LATEST FORMAT TO SHOW DUAL SEATING NIPPLE DESIGN. | 2023-07-15 VSP | CO-0229730 |

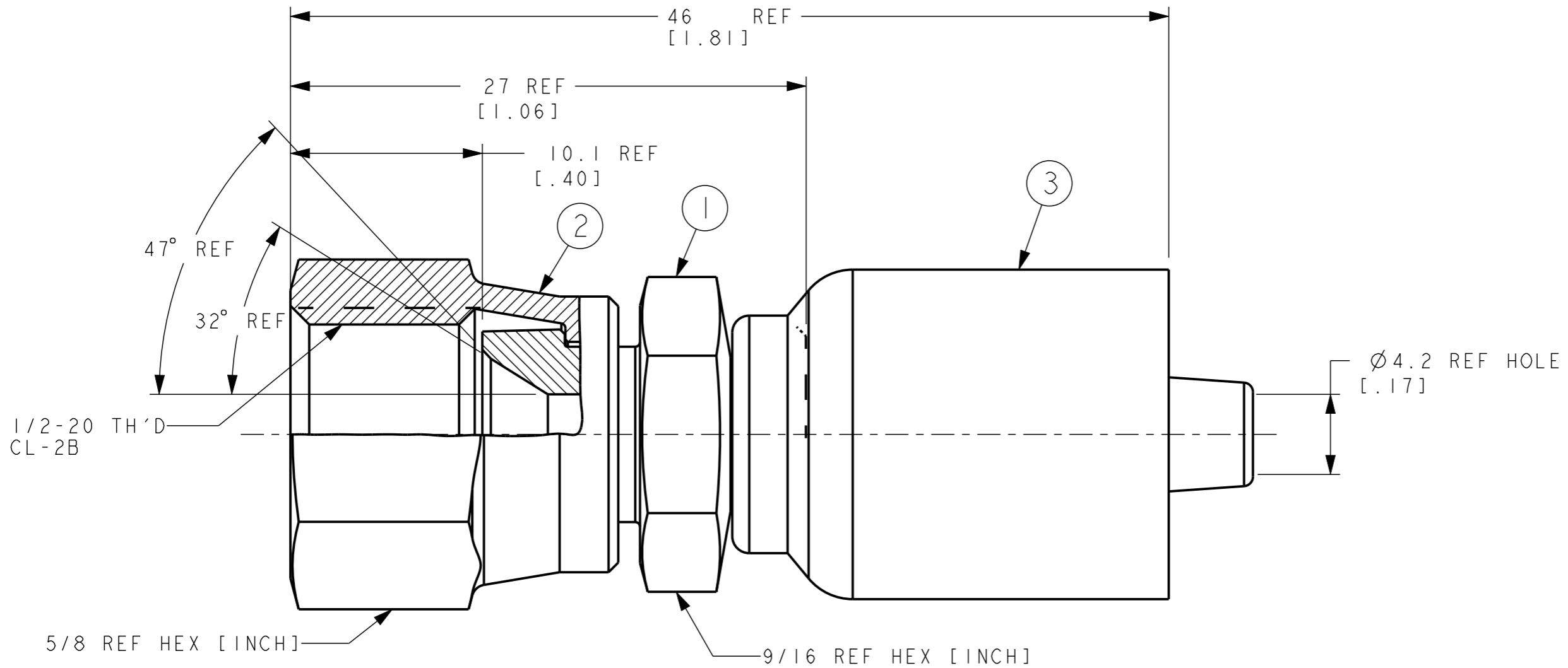

| | | | | | |
|-------------|----------------|-----------|----------|--|--|
| IGA5FJ4 | IF40000A0504-S | 210204-5S | IG4 | | |
| PART NUMBER | ① NIPPLE | ② NUT | ③ SOCKET | | |

LIST OF MATERIALS

| ITEM NO. | MATERIAL | FLUID CONVEYANCE DIVISION MAUMEE, OHIO U.S.A. | | DRAWN V. PATIL | |
|----------|----------|--|-----------------|--|------------|
| 1 | STEEL | | | CHECKED | V. PATIL |
| 2 | STEEL | | | APPROVED | B. JADHAV |
| 3 | STEEL | | | RELEASE DATE | 2023-07-15 |
| | | | | DRAWING INTERPRETATION PER ES 10 | |
| | | | | DRAWING TITLE | |
| | | | | FITTING ASSEMBLY | |
| | | | | HIGH PRESSURE SAE 37° FEMALE SWIVEL OTC | |
| | | CO-0229730 | CAGE CODE 01276 | DRAWING NUMBER | |
| | | THIRD ANGLE PROJECTION | DIST U | IGA5FJ4 | |
| | | SIZE A3 | SCALE 4/1 | REV | |
| | | SHEET 1 | | B | |

3. ISA5FJ4 NIPPLE ASSEMBLY MAY BE SUBSTITUTED FOR ITEMS #1 AND #2.
2. PROCESS AS FOLLOWS:
 - a) CRIMP NUT PER ACES 2813.
 - b) ASSEMBLE SOCKET PER ACES 2813.
1. DIMENSIONS ARE IN MILLIMETERS [INCHES].

THE REPRODUCTION, DISTRIBUTION, AND UTILIZATION OF THIS DOCUMENT AS WELL AS THE COMMUNICATION OF ITS CONTENTS TO OTHERS WITHOUT EXPLICIT AUTHORIZATION IS PROHIBITED. OFFENDERS WILL BE HELD LIABLE FOR THE PAYMENT OF DAMAGES. ALL RIGHTS RESERVED IN THE EVENT OF THE GRANT OF A PATENT, UTILITY MODEL OR DESIGN. (PER ISO 16016)