

DISPL CODE	D	C MAX
05	87.10±0.81 [3.429±.032]	104.17 [4.101]
08	91.17±0.81 [3.550±.032]	107.24 [4.222]
10	92.41±0.81 [3.638±.032]	109.47 [4.310]
12	94.62±0.81 [3.725±.032]	111.68 [4.397]
19	102.26±0.81 [4.026±.032]	119.33 [4.698]
30	113.61±0.81 [4.473±.032]	130.68 [5.145]

REV	DESCRIPTION	BY	DATE	ECN
A	ENGINEERING RELEASE	RAF	1-25-94	24688
B	<3D> REVISED C MAX TAB	RAF	3-15-94	25312
C	<4D>ADDED DISPL CODE 30	GCB	5-6-96	MIS295
D	-1><4D>ADDED DISP CODE 10 TO TABULATION BLOCK -2><3B><3C><2C>REVISED PICTORRIALLY -3>REVISED AS PER STACK UP -4>DRAWING UPDATED TO ASME Y14.5-2009 STANDARD	YUP	03-27-15	0062470

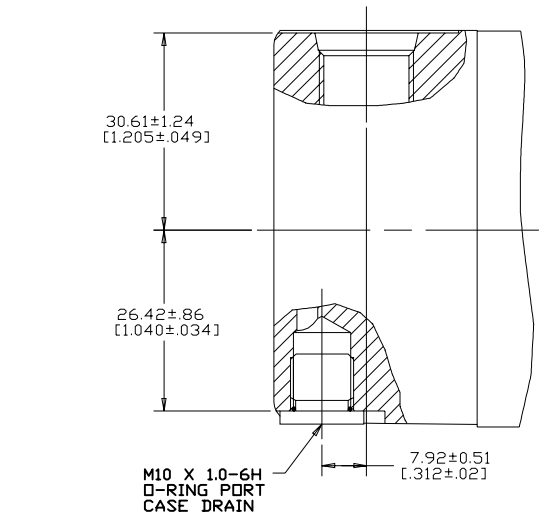
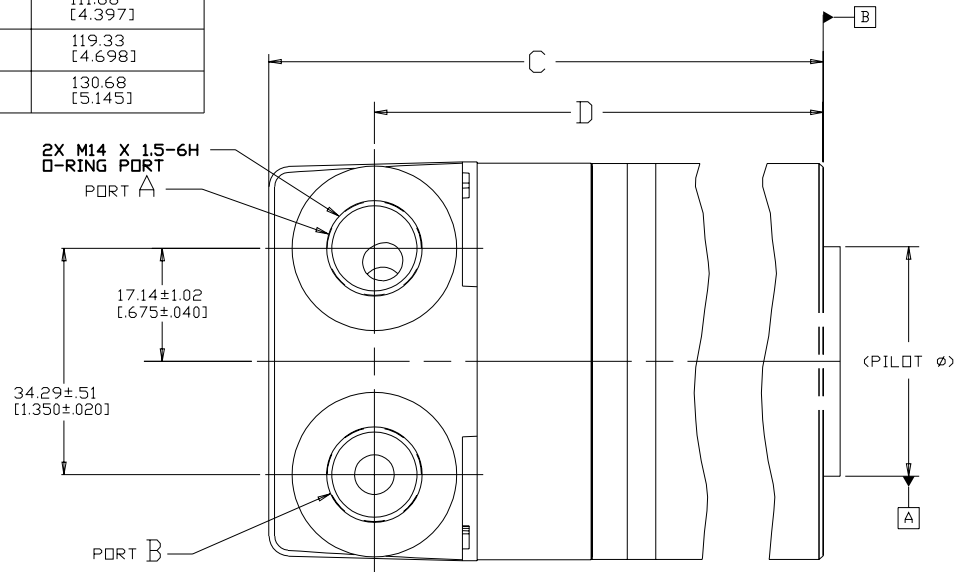

NOTE  
1 PORT TYPE G

REVIEWED FOR CLASSIFICATION PER ESP -042

UNLESS OTHERWISE SPECIFIED ALL DIMENSIONS ARE IN		DRAWING BASED ON ASME Y14.5-2009	
INCHES <input type="checkbox"/>	MILLIMETERS <input checked="" type="checkbox"/>	THE REPRODUCTION, DISTRIBUTION, AND UTILIZATION OF THIS DOCUMENT, AS WELL AS THE COMMUNICATION OF ITS CONTENTS TO OTHERS WITHOUT EXPLICIT AUTHORIZATION IS PROHIBITED. OFFENDERS WILL BE HELD LIABLE FOR THE PAYMENT OF DAMAGES. ALL RIGHTS RESERVED IN THE EVENT OF THE GRANT OF A PATENT, UTILITY MODEL, OR DESIGN. (PER ISO 18016)	
TOLERANCES		MATERIAL/HEAT TREAT	
x ± ----	xx ± REF		
xxx ± ONLY	checked BY/DATE AGJ 2/9/94	DRAWN BY/DATE RAF 1/27/94	
∠ ----	UNSPECIFIED RADII ARE	ENGRG BY/DATE WBW 2/9/94	
----	----	METALLURGY BY/DATE	
UNSPECIFIED DRAFT ANGLES ARE	THIRD ANGLE PROJECTION	TITLE	
----	DD NOT SCALE	J2 MOTOR PORT INSTALLATION	
D SIZE	ARITHMETICAL AVERAGE	NUMBER	
		A-818-007	
		SCALE	SHEET 1 OF 1
		2/1	

*Danfoss*