

REV	DESCRIPTION	BY	CHK	DATE	CO
A	ENGINEERING RELEASE	JLW	JGS	9/21/00	36517
B	UPDATED DRAWING TEMPLATE AS PER DANFOSS STANDARDS	SSP	TTM	11/30/22	CO-0226777

NOTE

- 1 ALL DIMENSIONS ARE NOMINAL UNLESS OTHERWISE SPECIFIED
- 2 MAX INPUT TORQUE NOT TO EXCEED 1215 Nm (10,750 IN LBS.)
- 3 STRAIGHT KEYED SHAFT OPTION COMPATIBLE WITH SAE-J744 SPECIFICATION

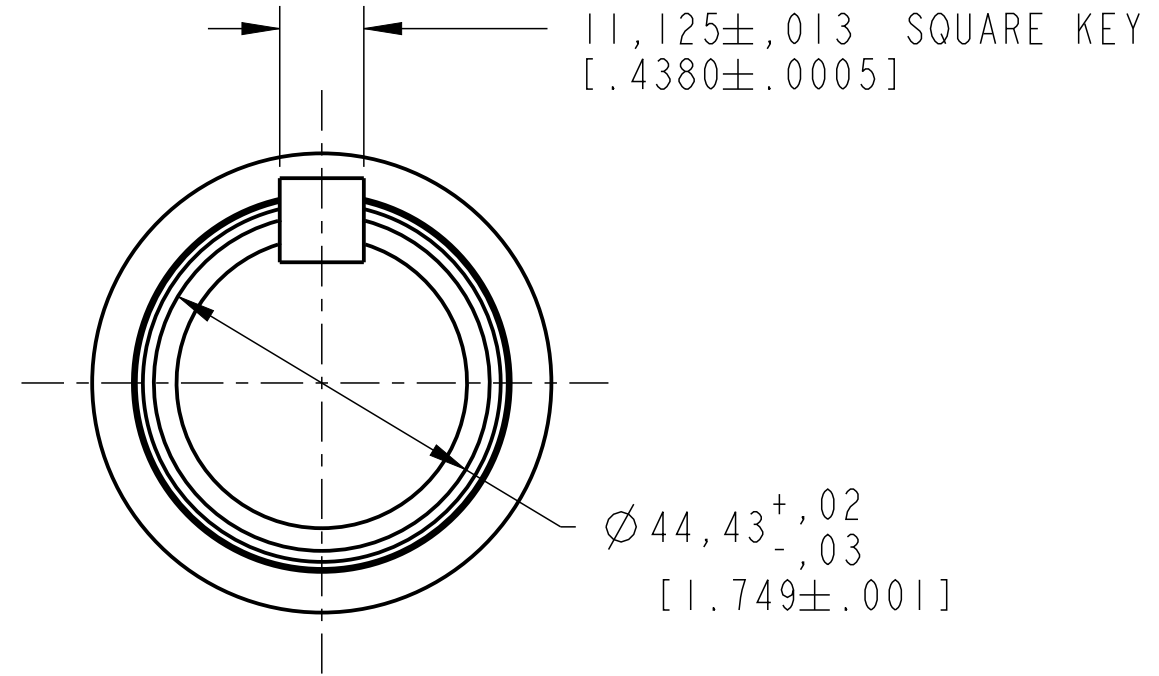
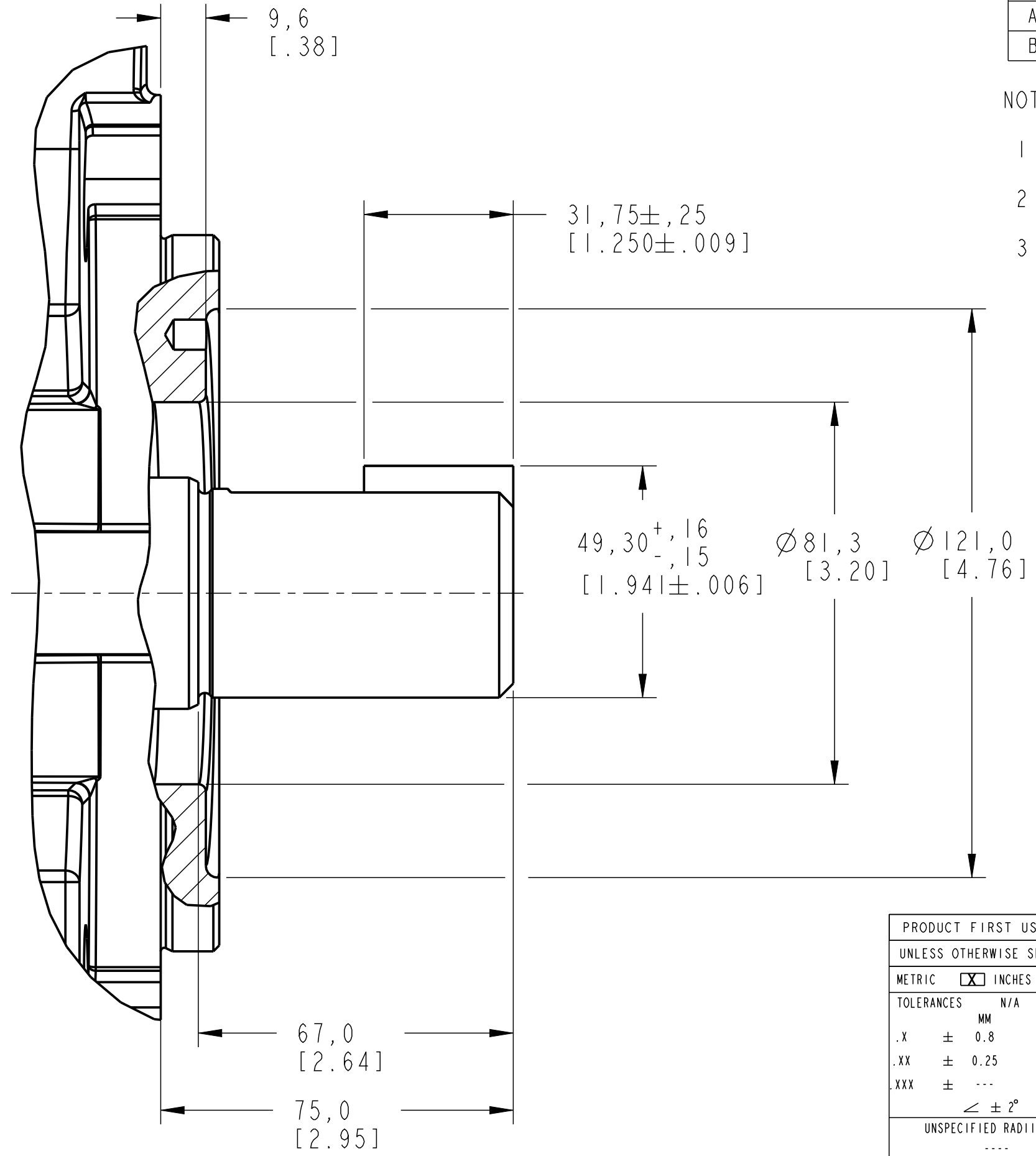

DRAWN BY/DATE	JLW	05/31/00
CHECKED BY/DATE	JGS	03/02/01
ENGRG BY/DATE	JL	03/02/01
MFG BY/DATE	---	---

PRODUCT FIRST USED ON : PVM PUMP		CHANGE ID		REV ITEMS	STATUS/DATE (DD/MM/YY)	RAW MATERIAL SPECIFICATION
UNLESS OTHERWISE SPECIFIED <input checked="" type="checkbox"/> LEGACY VICKERS ITEM INTERPRET PER VS 1-3-3-1		CO-0226777		B	ENGG RELEASE 30/11/22	---
METRIC <input checked="" type="checkbox"/> INCHES <input type="checkbox"/>	LAB OFFICE	UNSPECIFIED RADII ARE:		DRAWING INTERPRETATION PER 504H0074		
TOLERANCES	---	----		DWG NO A-2168-017 REV B		
.X ± 0.8 ± ---	UNSPECIFIED DRAFT ANGLES		DRAWING TITLE			
.XX ± 0.25 ± .03	----		SHAFT INSTALLATION			
.XXX ± --- ± .010	----		PART NO A-2168-017			
∠ ± 2°	SURFACE ROUGHNESS		SCALE 1/1		SHEET 1 OF 1	
NO BURRS	B SIZE		SHEET 1 OF 1		PART NO A-2168-017	

THE REPRODUCTION, DISTRIBUTION AND UTILIZATION OF THIS DOCUMENT AS WELL AS THE COMMUNICATION OF ITS CONTENTS TO OTHER WITHOUT EXPLICIT AUTHORIZATION IS PROHIBITED. OFFENDERS WILL BE HELD LIABLE FOR THE PAYMENT OF DAMAGES. ALL RIGHT RESERVED IN THE EVENT OF THE GRANT OF A PATENT, UTILITY MODEL OR DESIGN. (PER ISO 16016)

